

Weaving

Machines and accessories for the drawing-in process

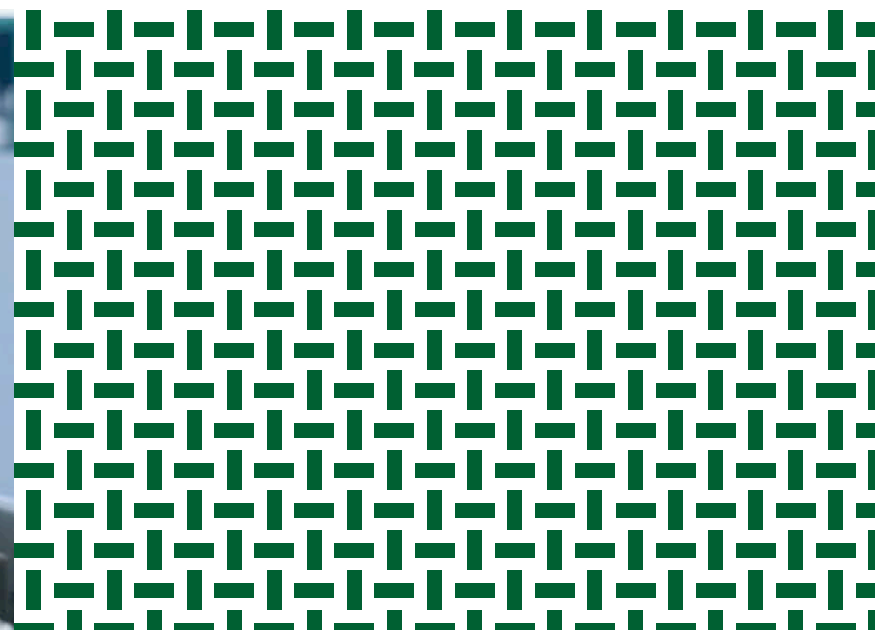

Machines and accessories from Groz-Beckert for the drawing-in process in weaving mills

Increased productivity in the weaving process starts with weaving preparation. Whether fully automated or manual drawing-in: Groz-Beckert guarantees maximum flexibility with minimal set-up requirements.

The drawing-in of the warp yarns is a key phase of the production process and has a significant impact on the quality and efficiency of the weaving mill. Groz-Beckert offers modern and efficient solutions for drawing in warp yarn.

The ever increasing performance and speed of modern weaving machines can only result in a true productivity increase if all associated processes are also highly efficient. A modern drawing-in system ensures that weaving machines are constantly equipped with drawn-in yarn to reduce downtimes during a warp change.

Weaving mills are increasingly facing demands for shorter delivery times. Fault-free production of the goods is also required. Mechanical drawing-in supports the smooth process in the weaving mill here.

With the WarpMaster, Groz-Beckert offers a system with intuitive operation, which efficiently supports the warp change thanks to the comprehensive level of automation.

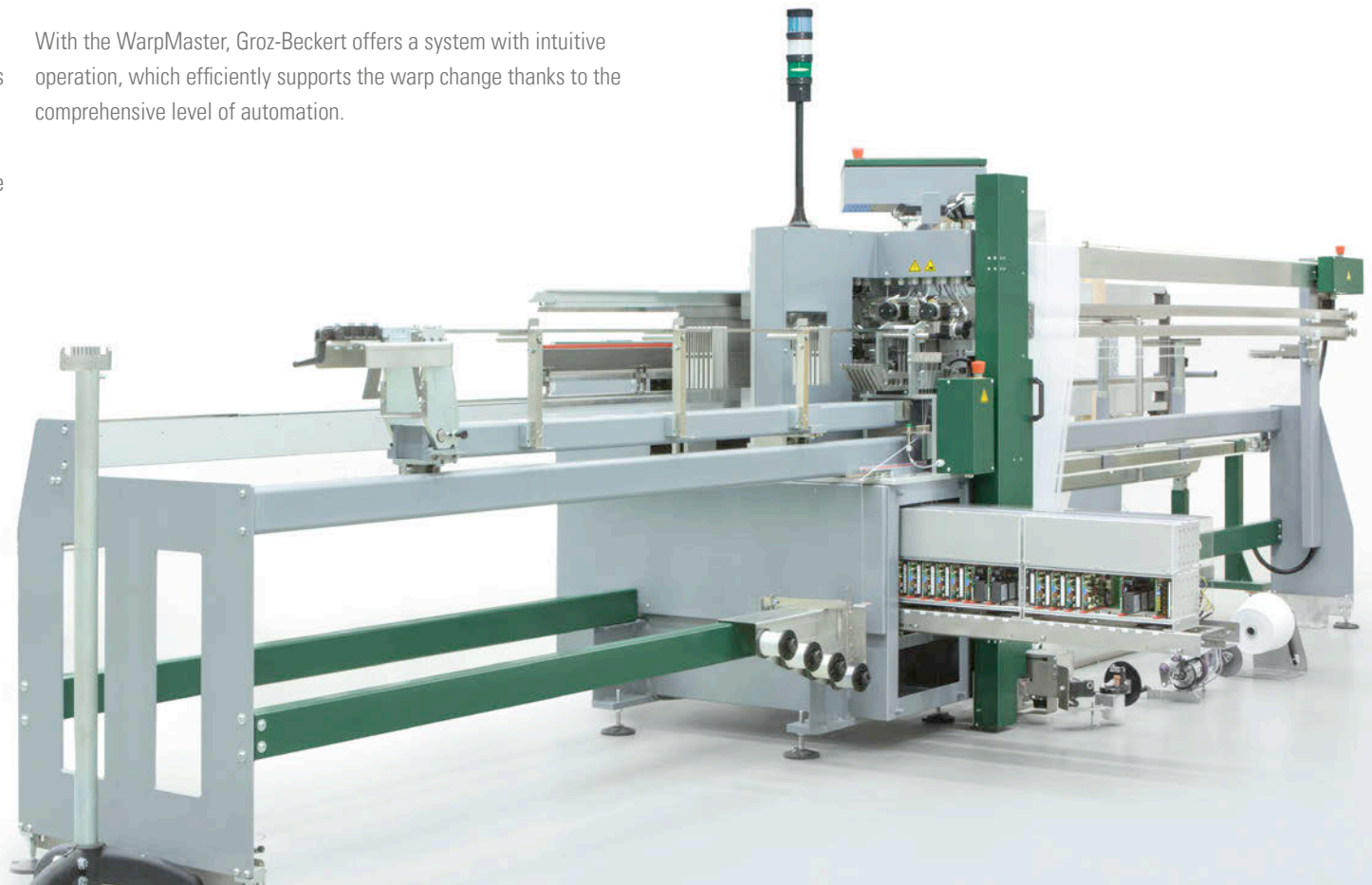
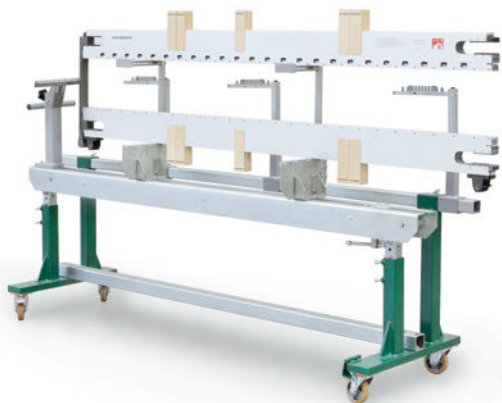

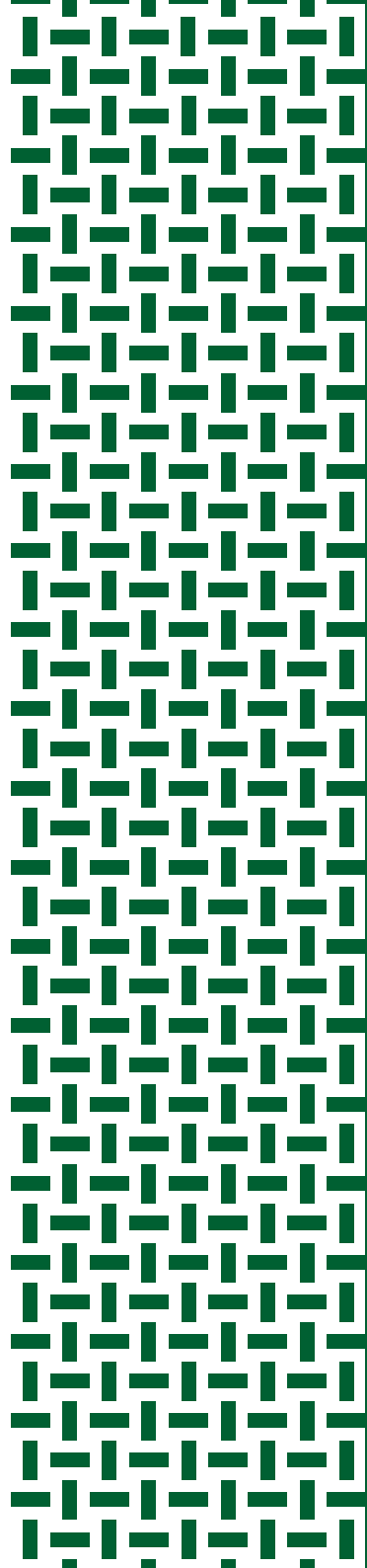

Contents

Machines and accessories for the drawing-in process in weaving mills	2
WarpMaster	
Drawing-in concept	5
Benefits	6
Technical details	7
Areas of application	8
Other machines for weaving preparation	9
Accessories for manual drawing-in	10

Overview of the Groz-Beckert WarpMaster

The Groz-Beckert WarpMaster represents a drawing-in concept that is established all over the world. The WarpMaster enables a fully automated and computer-controlled drawing-in process based on high-performance stepper motors, electromagnets and sensors. Because the yarn is drawn in from a single bobbin by drop wires, healds and reed, operation and conversion of the WarpMaster is easy and intuitive. Thanks to this drawing-in concept, the drawing-in process is carried out independently from the warp beam.

Customer benefits:

- Maximum flexibility in production
- Short payback period thanks to low pricing
- No problems with critical warp yarns, as the drawing-in takes place from a bobbin
- Worldwide established technology
- Particularly easy operation – with sensors and video support
- Individual adjustment options for machine widths from a length of 4 meters
- Optimal performance of the motors, as both the movement and the quality are monitored
- Constant monitoring of the magnet function
- Monitoring of the drawing-in accuracy via sensors
- Computer-controlled system with touchscreen, which shows different commands depending on the working operation
- Computer-controlled startup of the machine in the event of a stop

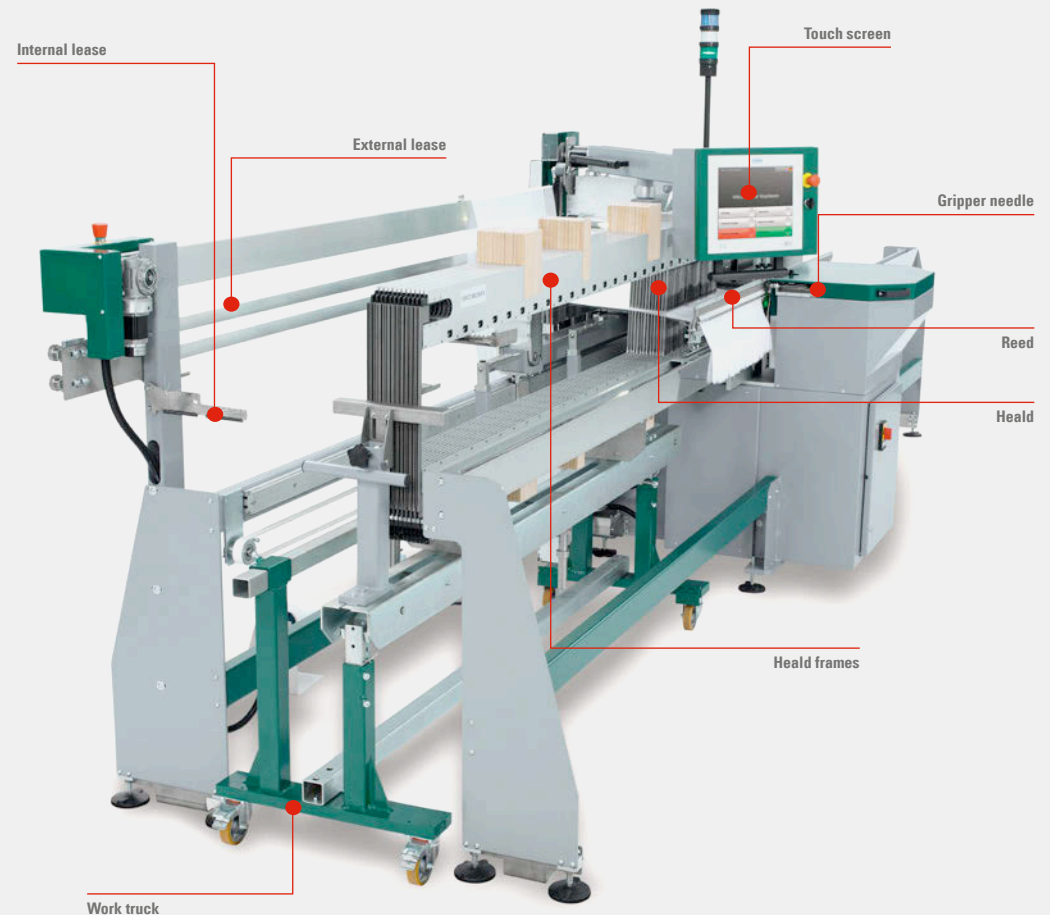

The drawing-in concept from Groz-Beckert

The WarpMaster is an easy to operate, fully automated drawing-in machine. The machine draws in the yarn from a single yarn bobbin via drop wires, healds and reed, meaning that the warp beam is not required for the drawing-in process.

This removes the need for time-intensive mounting of the warp threads. Setting adjustments due to changing warp materials are not required, which also saves time here. The drawing-in machine is suitable for using open healds with J- or C-shaped end loops.

Customer benefits:

- Drawing-in during the warp preparation
- Option of storing the drawing-ins without having to create the chains in advance
- Easy access to the weaving machine, which is particularly useful in restricted spaces
- Easy transport of the drawn-in harness, which is particularly useful in restricted spaces

Once the drawing-in process is complete, the entire harness is taken from the WarpMaster on the work trolley. The drawn-in harness is then transported to the weaving machine and tied to the warp beam. The WarpMaster can process up to 20 heald frames and up to 8 rows of drop wires depending on the machine type.

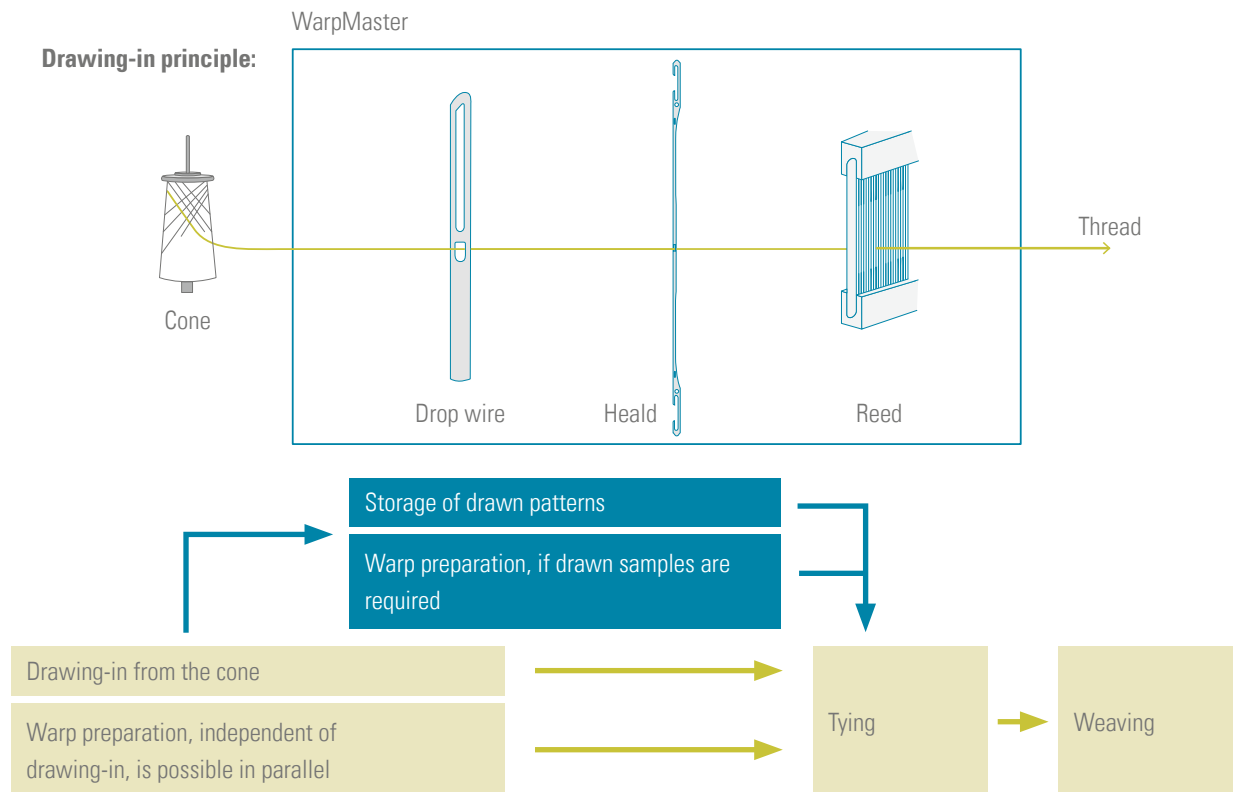

The advantages of the Groz-Beckert WarpMaster at a glance



Easy operation

- Short training times for operating and maintenance personnel
- Low training requirements
- Operation by just one person possible
- Easy setup and dismantling process



Video support

- Quick identification and removal of faults
- Modern, industrial touchscreen
- Easy programming and storage of drawing-in jobs
- Support with troubleshooting through offline videos
- Various languages available
- Online troubleshooting possible



Energy and space requirements

- Low energy consumption
- No compressed air connection required
- Low space requirements of the machine
- Easy transport and interim storage of drawing-ins without warp beam



Service

- Worldwide network of service technicians for maintenance and repair service
- Worldwide availability of spare parts
- Comprehensive service agreements
- Professional advice on individual uses
- Tests carried out by Groz-Beckert
- Trainings in the Groz-Beckert Academy
- Individual customer trainings on-site

External lease:

- Optimized lease position for the tying process on the weaving machine
- Option of an additional lease for monitoring purposes

Machine maintenance:

- Independent execution of necessary maintenance and servicing work possible, as all assemblies are easy to reach
- The entire control electronics are on a pull-out trolley

Specifications

Type	2400	4000
External dimensions WarpMaster	Length: 6.20 m	Length: 9.40 m
	Depth: 1.95 m	Depth: 1.95 m
	Height: 1.95 m	Height: 1.95 m
External dimensions work truck	Length: 2.65 m	Length: 4.25 m
	Depth: 0.70 m	Depth: 0.70 m
	Height: 1.35 m	Height: 1.35 m
Space requirement WarpMaster and work truck	3.4 m x 10 m	3.4 m x 15 m
Weight of WarpMaster	approx. 860 kg	approx. 1150 kg
Weight of work truck	approx. 250 kg	approx. 320 kg
Minimum space requirement	25 m ²	36 m ²
Compressed air	no	no
Power supply	110~240 VAC	110~240 VAC
	50~60 Hz	50~60 Hz
	below 1.65 KVA	below 1.65 KVA

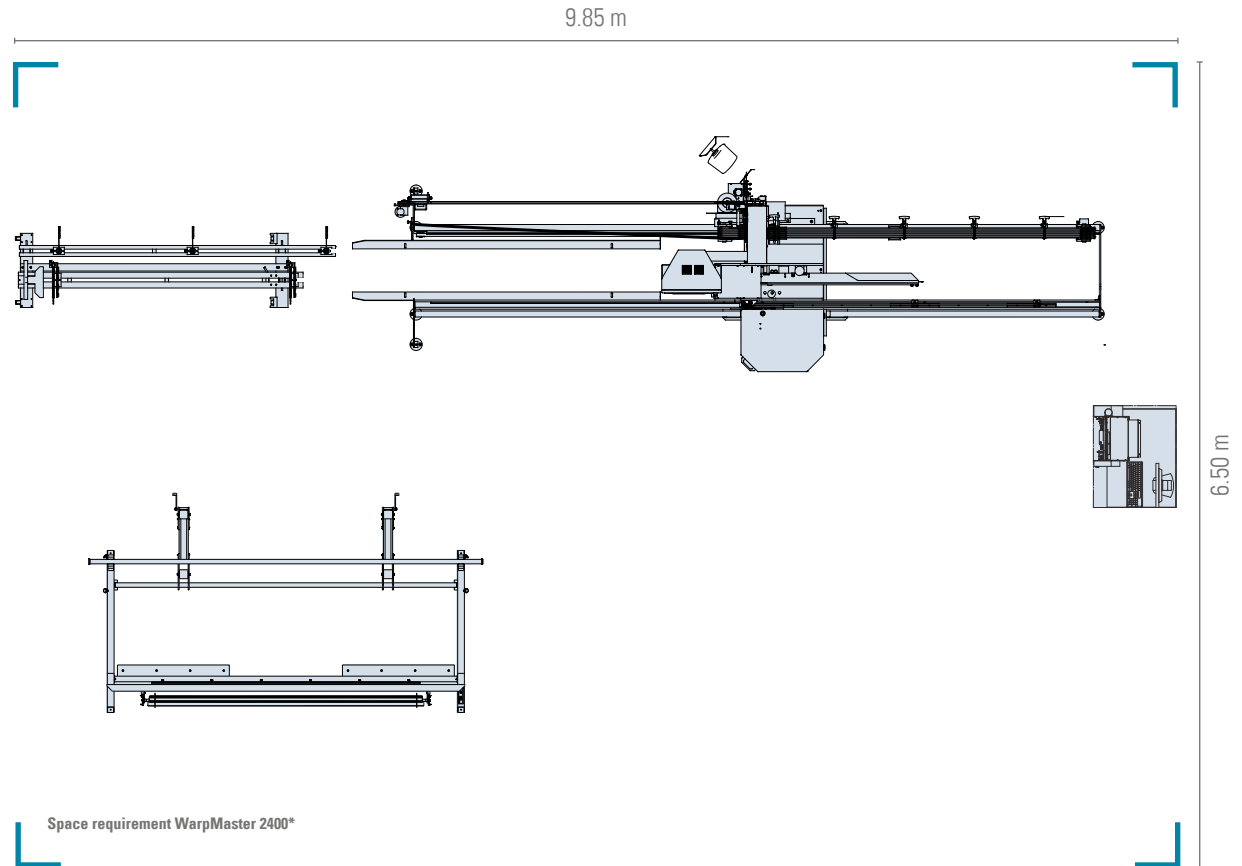

*) Space requirement WarpMaster 4000: 14.65 m x 6.50 m

The scope of application of the Groz-Beckert WarpMaster

The WarpMaster can be used for drawing-in a wide range of woven fabrics.



Technical fabrics



Jeans and natural white fabrics



Apparel fabrics



Upholstery fabrics

Advantages for technical woven fabrics:

- No setting adjustment on critical warp materials (glass, Kevlar, carbon) required, as the same yarn is always drawn in
- Drawing-in of fine reeds with pitches of up to 50/1 cm inclusive

Advantages for jeans and natural white woven fabrics:

- Manual drawing-in can take place via an automated drawing-in process with minimal personnel effort
- No wait time until the warp beam is prepared
- Transport of the harness independent from the warp beam

Advantages for apparel fabrics:

- Flexible reaction to short terms of delivery and small batch sizes
- Minimal process time: The drawing-in can be started at the same time as the warp beam creation
- Exclusion of drawing-in errors compared with manual drawing-in

Advantages for upholstery fabrics:

- Easy handling of double-beam woven fabrics through the creation of two 1:1 leases
- Easy transport of the drawn-in harness to the weaving machine

Further products from the field of weaving preparation

As an ideal addition to the WarpMaster, Groz-Beckert offers a complete machine system for drawing-in. With the additional devices, any weaving mill can adapt the drawing-in processes to the internal requirements in the company. Using the KnotMaster, for example, enables tying to take place on the weaving machine directly or in a preparatory step outside the weaving machine during the warp beam preparation.

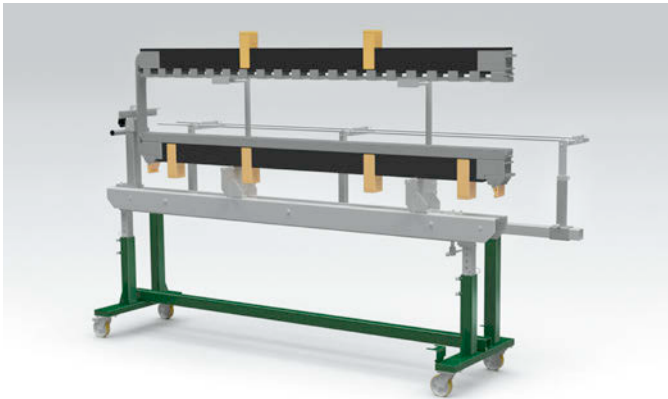

Worktruck

The worktruck holds the heald frames to be drawn in. The heald frames are lined up in line with their pitch with lateral supports removed on one side and fed into the WarpMaster. Once the drawing-in is complete, the heald frame is transferred to the worktruck complete with the drawn-in reed, healds and drop wires and removed from the machine. The WarpMaster is then immediately ready to receive the next worktruck. To ensure optimal utilization of the Groz-Beckert WarpMaster, we therefore recommend purchasing at least two worktrucks.



KnotPointPlus

The KnotPointPlus enables the drawing-ins created with the WarpMaster to be tied to the warp beam and drawn through outside of the weaving machine. The KnotPointPlus is therefore ideal for customers who want to create their drawing-ins with the WarpMaster from Groz-Beckert and also minimize the weaving machine downtimes (due to the changing of the harness). The KnotPointPlus is an easy to operate, stationary system, which enables the drawing-in coming from the WarpMaster to be tied to a warp beam independently from the weaving machine. With the brush roller integrated on the KnotPointPlus, the knots can be drawn through the harness safely and evenly. The tying process can also be moved from the weaving mill to the drawing-in phase.



KnotMaster

Under the name KnotMaster, Groz-Beckert offers high-performance tying machines with impressive technology and easy handling for a wide range of application fields. Customers benefit from rapid warp change and reduced idle times, and thereby from economical weaving preparation. Different series are available for standard and special applications.

Accessories for manual drawing-in

In addition to the fully automated drawing-in process – with the WarpMaster – Groz-Beckert also supports manual drawing-in. In concrete terms: Groz-Beckert also offers the suitable tools for easier drawing-in of the warp threads in the weaving machine through drop wires, healds and reeds

Drawing-in hooks and reed hooks are perfectly coordinated to the relevant applications through different designs.

1. Drawing-in hooks

The different production versions differ in cross section and length, as well as in the alignment of the blade. There are therefore drawing-in hooks with a straight or bent blade, with the opening positioned on the inside or outside as desired.

Drawing-in hooks are suitable for:

- Flat steel healds
- Healds for narrow fabric
- Wire healds
- Doup healds
- TWINtec healds
- Jacquard healds
- Rondofil® healds
- Drop wires

2. Reed hooks

Reed hooks are available for drawing-in warp thread through reeds. The Groz-Beckert portfolio includes two different types with a cross section of 6.5mm x 0.40mm and a length of 110 mm or 140 mm.



Groz-Beckert KG

Parkweg 2

72458 Albstadt, Germany

Phone +49 7431 10-0

Fax +49 7431 10-2777

contact-weaving@groz-beckert.com

www.groz-beckert.com

The depictions provided of our products are not to scale and are intended for illustrative purposes only. Consequently they make no claim to be an accurate representation of the original.

® = Registered trademark of the Groz-Beckert company group.

© = This publication is copyrighted.

All rights reserved, in particular the right of duplication, distribution and translation. This publication or any parts thereof may not be reproduced or stored, processed, duplicated or distributed using electronic systems in any form or by any means whatsoever without the express written consent of Groz-Beckert.

GROZ-BECKERT

KNITTING , WEAVING , FELTING , TUFTING , CARDING , SEWING

Weaving | EN | 08.2019

